

**- For Customer Signify-**

**OSRAM**

**IES LM-80-15 Test Report**

240279W1 – 2024-Oct-10

OSCONIQ<sup>®</sup> S 5050



# Test Report Of ANSI/IES LM-80-15

## Approved Method for Measuring Luminous Flux and Color Maintenance of LED Packages, Arrays and Modules

Report Number..... : N01A24081172L00101

Client..... : Osram Opto Semiconductors (M) Sdn. Bhd.

Address..... : Bayan Lepas FTZ 11900 Pulau Pinang, Malaysia

Test Model..... : GW Q9LR33.EM

Brand Name..... : OSCONIQ S 5050

Testing Laboratory... : Guangdong GTG Testing Technology Co., Ltd.

Address..... : 1st floor, B Area, Jinbaisheng Industrial Park, Headquarters 2 Road, Songshan Lake Hi-tech Industrial Development Zone, Dongguan City, Guangdong Pr., China.

Testing Location..... : As above

Date of receipt..... : 2022-09-01

Date of test ..... : 2022-09-02 to 2024-09-11

Date of report..... : 2024-09-13

Tested by:

*Sujay Zhou*

Sujay Zhou/ Test Engineer

Checked by:

*Sandy Chen*

Sandy Chen/ Project Engineer

Approved by:



Jessie Li/ Technical Manager

Note 1: The test data was only valid for the test sample(s). This test report is prepared for the customer shown above and for the device described herein. It may not be duplicated or use in part without prior written consent from Guangdong GTG Testing Technology Co., Ltd. This report must not be used by the customer to claim product certification, approval, or endorsement by NVLAP, NIST, or any agency of the Federal Government.

Note 2: This report does not imply product certification, approval, or endorsement by NVLAP, NIST, or any agency of the Federal Government.

**ENERGY STAR® LM-80 Cover Sheet****Administrative Information**

Tested subcomponent series: EMC 5050 LED

Tested subcomponent model number: GW Q9LR33.EM

**DUT Identification**

DUT manufacture's name: Osram Opto Semiconductors (M) Sdn. Bhd.

DUT identification, e.g., model number: GW Q9LR33.EM

Description of DUT, including if the DUT is an LED  
package or module: LED Package**DUT Characteristics**

Total input power(W): 4.8 W

Average current density per LED die(mA/mm<sup>2</sup>): 300 mA/mm<sup>2</sup>Average power density per LED package(W/mm<sup>2</sup>): 0.19 W/mm<sup>2</sup>Representative CRI(Ra) of the tested sample set: 80  
(Indicate whether the reported value is the mean or  
Median value of the sample set, or per unit)

Minimum die edge to die edge spacing: 0.05 mm

**Table of Contents**

1. General Information .....	4
1.1 Description of LED Light Sources .....	4
1.2 Standards Used .....	4
1.3 Test equipment list .....	4
1.4 Drive Level .....	5
1.5 Ambient Conditions for Maintenance Test .....	5
1.6 Photometric Measurement Method .....	5
1.7 Sample Set .....	6
2. Summary of Test Result .....	7
3. Test Data .....	9
3.1 Data Set 1, 55°C, 800mA (Lumen Maintenance) .....	9
3.2 Data Set 1, 55°C, 800mA (Forward Voltage) .....	10
3.3 Data Set 1, 55°C, 800mA (Chromaticity Shift) .....	11
3.4 Data Set 2, 85°C, 800mA (Lumen Maintenance) .....	12
3.5 Data Set 2, 85°C, 800mA (Forward Voltage) .....	13
3.6 Data Set 2, 85°C, 800mA (Chromaticity Shift) .....	14
3.7 Data Set 3, 105°C, 800mA (Lumen Maintenance) .....	15
3.8 Data Set 3, 105°C, 800mA (Forward Voltage) .....	16
3.9 Data Set 3, 105°C, 800mA (Chromaticity Shift) .....	17
4. EUT Photo .....	18
4.1 Mechanical Dimensions .....	18
4.2 EUT Photo .....	18

## 1. General Information

### 1.1 Description of LED Light Sources

#### Sample Size:

75Pcs samples were received on 2022-09-01, the samples were numbered from S1 to S75. (Sample No. A24081172 001 to A24081172 075 will be replaced with S1 to S75.)

Manufacture: Osram Opto Semiconductors (M) Sdn. Bhd.

Part Number: GW Q9LR33.EM

Part Type: LED Package

Drive Level: DC 800mA

Nominal CCT: 2700K

Power: 4.8W

CRI: 80

#### Sampling Method:

LED samples for IESNA LM-80 testing consist of units built from three manufacturing lots with each manufacturing lot built from different wafer lots built on non-consecutive days.

These manufacturing lots are picked to represent a wide parametric distribution.

### 1.2 Standards Used

- ANSI/IES LM-80-15 IES Approved Method for Luminous Flux and Color Maintenance of LED Packages, Arrays and Modules
- IES TM-21-11: Projecting Long Term Lumen Maintenance of LED Light Sources (This standard was not accredited by NVLAP)
- ENERGY STAR® Requirements for the use of LM-80 Data (This standard was not accredited by NVLAP)

### 1.3 Test equipment list

Test Equipment	Serial No	Model No	Calibration due date
Integrating Sphere System	01-L-187	0.5m	2025/03/13
Standard Light Source	01-L-188	D062	2025/03/13
High Accuracy Array Spectroradio Meter	01-L-169	HAAS-3000	2025/03/13
Digital Power Meter	01-L-166	PF310	2025/03/13
Precision digital stabilized DC power supply	01-L-167	WY305	2025/03/13
Temperature Tester	01-L-192	UIS-D8036	2025/02/22

Statement of Traceability: Guangdong GTG Testing Technology Co., Ltd. attested that all calibration has been performed using suitable standards traceable to national primary standards and International System of Unit(SI).

#### 1.4 Drive Level

Samples are driven with a constant direct current (DC) during maintenance test, photometric and electrical measurement. The current value was regulated to within  $\pm 3\%$  of the specified value of the manufacturer during maintenance test, and was within  $\pm 0.5\%$  during photometric and electrical measurement test.

#### 1.5 Ambient Conditions for Maintenance Test

For lumen maintenance test, samples within one data set, were installed on cooling boards in thermal chambers with minimal ambient airflow. The case temperature and ambient temperature was monitored by thermocouples which one was soldered to the coldest DUTs' case ( $TMP_{LED}$ ) location, while the other is mounted at a distance of 5 mm above the TMP location. During life testing,  $TMP_{LED}$  of the coldest LEDs were maintained at a temperature that was greater than or equal to  $2^{\circ}\text{C}$  below the corresponding nominal case temperature. Surrounding air was maintained at a temperature that was greater than or equal to  $5^{\circ}\text{C}$  below the corresponding nominal case temperature. Thermocouples were shielded from direct DUT optical radiation and comply with ASTM E230 Table 1 "Special Limits". Samples were connected to DC power supply in series circuits with a constant current. The forward current was regulated to within  $\pm 3\%$  of the specified value of the manufacturer. The relative humidity within chamber was kept less than 65% during test. For photometry measurement, the ambient temperature during test was set to  $25^{\circ}\text{C} \pm 2^{\circ}\text{C}$ ,  $\text{RH} < 65\%$ .

#### 1.6 Photometric Measurement Method

Integrating sphere and spectroradiometer is used to measure luminous flux and chromaticity coordinate  $u'v'$ .  $2\pi$  measurement was used and sample was driven by DC power supply. The forward current was regulated to within  $\pm 0.5\%$  of the nominal value. The test system was calibrated by halogen reference lamp. The ambient temperature during test was set to  $25^{\circ}\text{C} \pm 2^{\circ}\text{C}$ ,  $\text{RH} < 65\%$ . The temperature measurement point was located in the sphere and the temperature was detected by a temperature probe. The uncertainty of the light output (luminous flux) measurements is  $U=2.1\%$  ( $K=2$ ), at the 95% confidence level. The uncertainty of the correlated color temperature measurements is  $U=18\text{K}$  ( $K=2$ ), at the 95% confidence level. The uncertainty of the temperature is  $U=0.5^{\circ}\text{C}$  ( $K=2$ ), at the 95% confidence level.

**1.7 Sample Set**

<b>Data Set 1:55°C,800mA</b>	
Part number:	GW Q9LR33.EM
Number of Units:	25
Case Temperature( $T_S$ ):	> 53°C
Ambient Temperature( $T_A$ ):	> 50°C
Life Test Drive Current:	800mA
Measurement Current:	800mA

<b>Data Set 2:85°C,800mA</b>	
Part number:	GW Q9LR33.EM
Number of Units:	25
Case Temperature( $T_S$ ):	> 83°C
Ambient Temperature( $T_A$ ):	> 80°C
Life Test Drive Current:	800mA
Measurement Current:	800mA

<b>Data Set 3:105°C,800mA</b>	
Part number:	GW Q9LR33.EM
Number of Units:	25
Case Temperature( $T_S$ ):	> 103°C
Ambient Temperature( $T_A$ ):	> 100°C
Life Test Drive Current:	800mA
Measurement Current:	800mA

## 2. Summary of Test Result

Data Set:	Nominal Case & Ambient Temp.	Sample Size	Failures Observed:	Test Interval	Test Duration	$\alpha$	B	Reported TM-21 L <sub>70</sub> Lifetime	Reported TM-21 L <sub>90</sub> Lifetime
1	55°C	25	0	1000hrs	17000hrs	9.192E-07	0.998	>102000hours	>102000hours
2	85°C	25	0	1000hrs	17000hrs	9.437E-07	0.995	>102000hours	>102000hours
3	105°C	25	0	1000hrs	17000hrs	1.739E-06	0.998	>102000hours	60000hours

### Average Lumen Maintenance (Percentage of Initial Luminous Flux)

Data Set:	1000hrs	2000hrs	3000hrs	4000hrs	5000hrs	6000hrs	7000hrs	8000hrs	9000hrs	10000hrs	11000hrs	12000hrs	13000hrs	14000hrs	15000hrs	16000hrs	17000hrs
1	100.16%	100.01%	99.87%	99.69%	99.50%	99.32%	99.20%	99.06%	98.94%	98.83%	98.75%	98.64%	98.55%	98.46%	98.37%	98.31%	98.25%
2	100.07%	99.92%	99.72%	99.52%	99.32%	99.13%	98.98%	98.84%	98.70%	98.56%	98.47%	98.38%	98.29%	98.20%	98.12%	98.06%	97.98%
3	99.91%	99.72%	99.52%	99.31%	99.09%	98.87%	98.68%	98.49%	98.30%	98.10%	97.94%	97.76%	97.57%	97.39%	97.24%	97.10%	96.99%

### Average Chromaticity Shift ( $\Delta u'v'$ )

Data Set:	1000hrs	2000hrs	3000hrs	4000hrs	5000hrs	6000hrs	7000hrs	8000hrs	9000hrs	10000hrs	11000hrs	12000hrs	13000hrs	14000hrs	15000hrs	16000hrs	17000hrs
1	0.0001	0.0003	0.0005	0.0006	0.0007	0.0007	0.0008	0.0008	0.0009	0.0009	0.0010	0.0010	0.0011	0.0011	0.0012	0.0012	0.0013
2	0.0002	0.0004	0.0006	0.0008	0.0010	0.0012	0.0014	0.0015	0.0016	0.0018	0.0020	0.0022	0.0024	0.0026	0.0028	0.0030	0.0032
3	0.0003	0.0005	0.0008	0.0010	0.0013	0.0014	0.0017	0.0019	0.0020	0.0021	0.0022	0.0024	0.0026	0.0028	0.0030	0.0032	0.0035

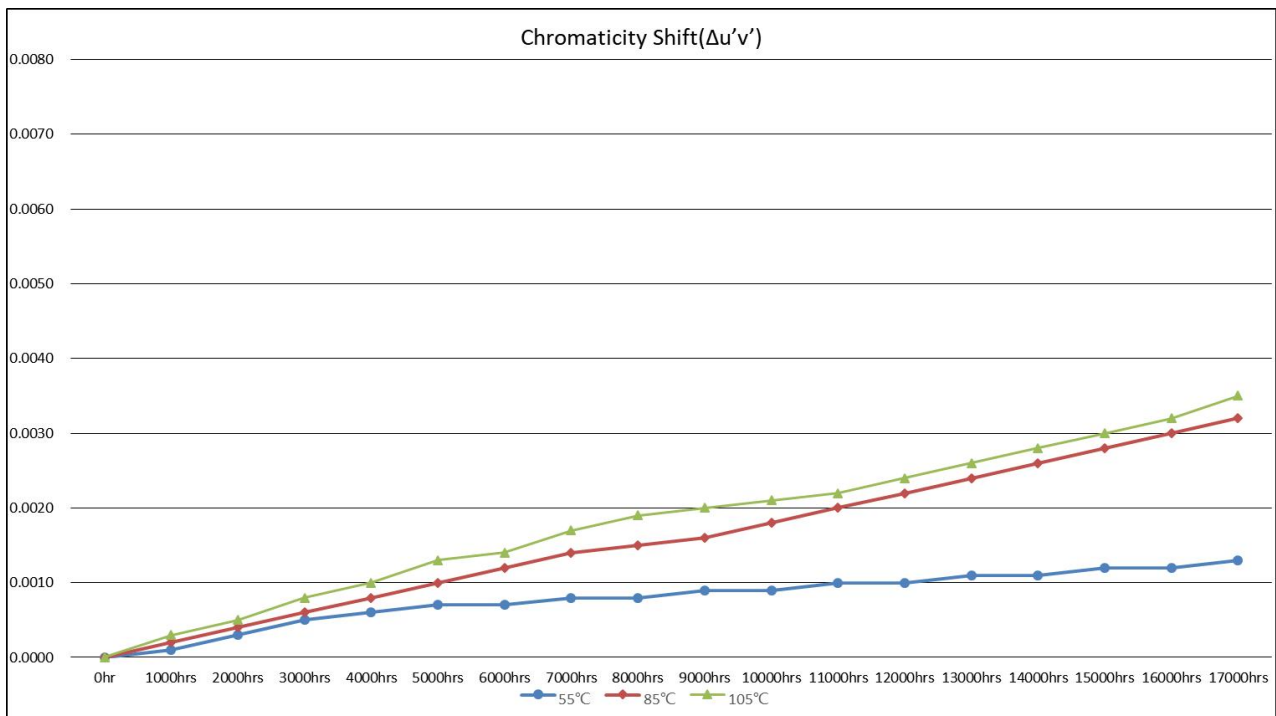
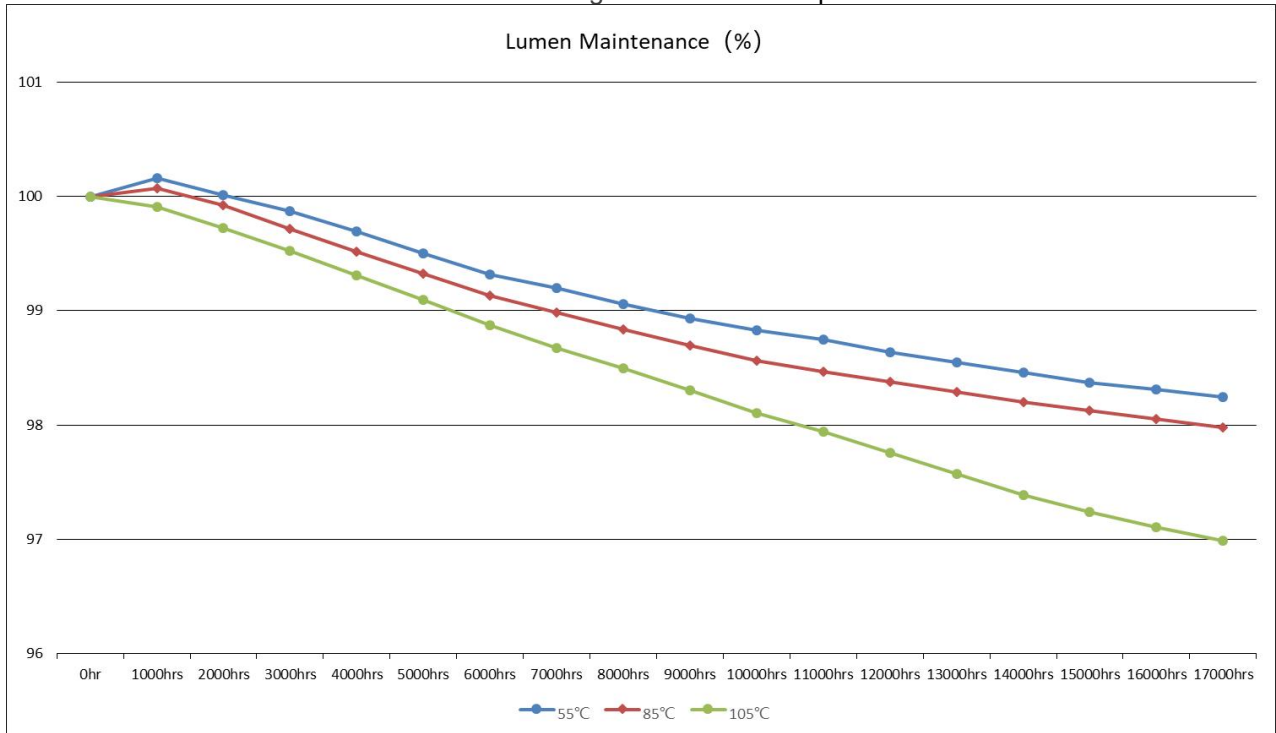

### 3. Test Data

#### 3.1 Data Set 1, 55°C, 800mA (Lumen Maintenance)

Sample Number	Φ(lm)	Lumen Maintenance (%)																
	0hr (Initial)	1000 hrs	2000 hrs	3000 hrs	4000 hrs	5000 hrs	6000 hrs	7000 hrs	8000 hrs	9000 hrs	10000 hrs	11000 hrs	12000 hrs	13000 hrs	14000 hrs	15000 hrs	16000 hrs	17000 hrs
S1	644.51	100.17	100.03	99.89	99.75	99.55	99.35	99.23	99.08	98.96	98.86	98.79	98.69	98.59	98.50	98.41	98.36	98.32
S2	644.07	100.11	99.97	99.83	99.69	99.50	99.30	99.18	99.04	98.89	98.79	98.72	98.62	98.55	98.47	98.38	98.33	98.29
S3	643.02	100.19	100.05	99.91	99.72	99.53	99.36	99.23	99.11	99.00	98.90	98.83	98.73	98.63	98.53	98.45	98.36	98.31
S4	644.26	100.19	100.05	99.91	99.72	99.52	99.32	99.19	99.08	98.93	98.80	98.73	98.63	98.53	98.44	98.35	98.30	98.26
S5	645.25	100.20	100.06	99.91	99.77	99.58	99.44	99.33	99.18	99.04	98.94	98.87	98.77	98.68	98.58	98.50	98.45	98.41
S6	644.43	100.14	100.00	99.85	99.66	99.47	99.33	99.21	99.09	98.96	98.86	98.79	98.66	98.57	98.49	98.42	98.32	98.27
S7	643.79	100.15	100.01	99.87	99.68	99.48	99.28	99.16	99.02	98.90	98.80	98.73	98.60	98.50	98.41	98.33	98.23	98.19
S8	645.91	100.11	99.97	99.83	99.69	99.49	99.29	99.17	99.03	98.91	98.81	98.71	98.61	98.51	98.41	98.31	98.27	98.17
S9	645.48	100.10	99.97	99.82	99.63	99.43	99.23	99.11	98.98	98.86	98.76	98.69	98.56	98.48	98.39	98.30	98.25	98.16
S10	644.27	100.16	100.01	99.87	99.74	99.60	99.41	99.26	99.11	98.97	98.87	98.77	98.67	98.57	98.47	98.40	98.35	98.25
S11	644.11	100.11	99.97	99.82	99.62	99.42	99.28	99.16	99.02	98.89	98.76	98.69	98.59	98.50	98.41	98.33	98.29	98.19
S12	642.56	100.10	99.95	99.81	99.61	99.41	99.22	99.10	98.98	98.86	98.73	98.66	98.53	98.43	98.34	98.25	98.20	98.16
S13	644.72	100.11	99.97	99.83	99.63	99.44	99.24	99.10	98.95	98.83	98.73	98.66	98.53	98.44	98.34	98.24	98.14	98.09
S14	643.99	100.18	100.04	99.90	99.70	99.56	99.42	99.28	99.15	99.04	98.91	98.80	98.71	98.63	98.53	98.43	98.38	98.34
S15	642.29	100.21	100.06	99.92	99.78	99.65	99.45	99.30	99.18	99.06	98.96	98.89	98.79	98.69	98.59	98.52	98.42	98.37
S16	642.60	100.17	100.03	99.89	99.75	99.55	99.36	99.24	99.10	98.95	98.85	98.78	98.68	98.61	98.51	98.43	98.38	98.34
S17	642.04	100.20	100.06	99.92	99.72	99.52	99.33	99.21	99.09	98.94	98.84	98.77	98.64	98.55	98.47	98.37	98.33	98.23
S18	644.24	100.13	99.99	99.85	99.65	99.46	99.26	99.14	98.99	98.87	98.77	98.67	98.57	98.47	98.40	98.30	98.26	98.21
S19	643.86	100.19	100.05	99.91	99.71	99.51	99.37	99.26	99.14	99.03	98.93	98.86	98.76	98.67	98.59	98.49	98.44	98.40
S20	643.59	100.19	100.05	99.90	99.70	99.51	99.31	99.16	99.02	98.90	98.76	98.66	98.56	98.50	98.42	98.36	98.26	98.16
S21	643.89	100.10	99.96	99.82	99.62	99.42	99.28	99.17	99.02	98.91	98.81	98.74	98.64	98.54	98.46	98.37	98.32	98.28
S22	642.17	100.21	100.07	99.92	99.73	99.53	99.33	99.20	99.08	98.96	98.86	98.79	98.66	98.58	98.48	98.39	98.29	98.25
S23	642.45	100.15	100.01	99.86	99.66	99.46	99.26	99.14	98.99	98.85	98.71	98.61	98.51	98.42	98.34	98.25	98.21	98.11
S24	644.02	100.12	99.97	99.83	99.64	99.45	99.26	99.14	99.02	98.90	98.80	98.70	98.57	98.48	98.38	98.28	98.24	98.14
S25	642.96	100.18	100.04	99.91	99.71	99.52	99.33	99.21	99.09	98.98	98.84	98.77	98.67	98.60	98.50	98.40	98.36	98.32
Ave.	643.78	100.16	100.01	99.87	99.69	99.50	99.32	99.20	99.06	98.94	98.83	98.75	98.64	98.55	98.46	98.37	98.31	98.25
Med.	643.99	100.16	100.01	99.87	99.70	99.51	99.32	99.19	99.08	98.93	98.81	98.74	98.64	98.55	98.47	98.37	98.32	98.25
St dev	1.0448	0.0386	0.0384	0.0389	0.0496	0.0597	0.0637	0.0607	0.0644	0.0634	0.0673	0.0720	0.0768	0.0763	0.0745	0.0773	0.0779	0.0896
Min.	642.04	100.10	99.95	99.81	99.61	99.41	99.22	99.10	98.95	98.83	98.71	98.61	98.51	98.42	98.34	98.24	98.14	98.09
Max.	645.91	100.21	100.07	99.92	99.78	99.65	99.45	99.33	99.18	99.06	98.96	98.89	98.79	98.69	98.59	98.52	98.45	98.41

## 3.2 Data Set 1, 55°C, 800mA (Forward Voltage)

Sample Number	Forward Voltage(V)																	
	0hr (Initial)	1000 hrs	2000 hrs	3000 hrs	4000 hrs	5000 hrs	6000 hrs	7000 hrs	8000 hrs	9000 hrs	10000 hrs	11000 hrs	12000 hrs	13000 hrs	14000 hrs	15000 hrs	16000 hrs	17000hrs
S1	6.300	6.302	6.301	6.294	6.287	6.286	6.290	6.289	6.283	6.284	6.271	6.279	6.275	6.269	6.273	6.271	6.272	6.260
S2	6.290	6.289	6.279	6.280	6.277	6.277	6.272	6.267	6.266	6.275	6.262	6.273	6.271	6.260	6.261	6.254	6.263	6.255
S3	6.298	6.300	6.291	6.295	6.289	6.280	6.284	6.287	6.286	6.285	6.280	6.276	6.279	6.267	6.270	6.257	6.272	6.261
S4	6.300	6.290	6.290	6.294	6.296	6.288	6.292	6.283	6.281	6.273	6.287	6.278	6.268	6.274	6.263	6.271	6.264	6.265
S5	6.289	6.291	6.289	6.279	6.286	6.281	6.282	6.271	6.278	6.261	6.273	6.262	6.269	6.261	6.262	6.252	6.260	6.248
S6	6.288	6.281	6.281	6.286	6.273	6.271	6.270	6.274	6.277	6.270	6.272	6.266	6.268	6.257	6.262	6.260	6.261	6.248
S7	6.300	6.293	6.302	6.294	6.294	6.292	6.280	6.286	6.282	6.283	6.273	6.273	6.269	6.272	6.264	6.269	6.263	6.261
S8	6.298	6.298	6.287	6.282	6.284	6.292	6.278	6.284	6.277	6.269	6.269	6.271	6.278	6.265	6.271	6.261	6.261	6.265
S9	6.299	6.302	6.298	6.293	6.292	6.293	6.279	6.288	6.276	6.286	6.281	6.272	6.268	6.279	6.270	6.262	6.269	6.267
S10	6.297	6.286	6.292	6.292	6.288	6.290	6.288	6.286	6.279	6.281	6.270	6.275	6.265	6.267	6.271	6.258	6.260	6.265
S11	6.295	6.296	6.294	6.288	6.280	6.277	6.275	6.271	6.278	6.267	6.277	6.268	6.268	6.264	6.268	6.266	6.256	6.269
S12	6.298	6.298	6.300	6.296	6.291	6.291	6.281	6.287	6.274	6.276	6.282	6.271	6.266	6.270	6.262	6.272	6.269	6.271
S13	6.295	6.284	6.293	6.285	6.289	6.275	6.288	6.277	6.280	6.275	6.275	6.268	6.268	6.263	6.254	6.256	6.254	6.268
S14	6.293	6.293	6.282	6.286	6.287	6.287	6.286	6.274	6.272	6.276	6.264	6.266	6.262	6.262	6.266	6.257	6.265	6.253
S15	6.296	6.298	6.298	6.293	6.281	6.286	6.278	6.282	6.273	6.271	6.276	6.269	6.265	6.264	6.267	6.270	6.257	6.270
S16	6.291	6.280	6.286	6.286	6.282	6.270	6.277	6.267	6.267	6.274	6.262	6.264	6.264	6.259	6.254	6.262	6.254	6.251
S17	6.300	6.295	6.289	6.285	6.284	6.293	6.286	6.281	6.283	6.287	6.282	6.273	6.269	6.269	6.264	6.269	6.269	6.260
S18	6.297	6.299	6.300	6.292	6.292	6.279	6.291	6.285	6.280	6.281	6.275	6.275	6.265	6.269	6.267	6.270	6.268	6.256
S19	6.296	6.295	6.285	6.286	6.286	6.289	6.278	6.275	6.277	6.280	6.271	6.281	6.269	6.271	6.268	6.260	6.267	6.262
S20	6.289	6.291	6.284	6.274	6.273	6.279	6.283	6.273	6.265	6.276	6.272	6.262	6.258	6.263	6.261	6.253	6.248	6.249
S21	6.291	6.291	6.280	6.286	6.276	6.282	6.274	6.274	6.280	6.266	6.278	6.269	6.261	6.264	6.250	6.262	6.250	6.251
S22	6.295	6.288	6.288	6.290	6.285	6.278	6.281	6.284	6.271	6.267	6.266	6.268	6.265	6.264	6.268	6.269	6.268	6.262
S23	6.287	6.285	6.288	6.273	6.274	6.278	6.273	6.273	6.270	6.274	6.271	6.265	6.257	6.259	6.260	6.256	6.250	6.250
S24	6.289	6.284	6.278	6.283	6.287	6.283	6.275	6.266	6.275	6.276	6.262	6.262	6.270	6.259	6.260	6.252	6.263	6.249
S25	6.293	6.296	6.292	6.290	6.291	6.279	6.275	6.282	6.272	6.271	6.277	6.273	6.265	6.261	6.256	6.263	6.254	6.253
Ave.	6.295	6.292	6.290	6.287	6.285	6.283	6.281	6.278	6.276	6.275	6.273	6.270	6.267	6.265	6.264	6.262	6.261	6.259
Med.	6.295	6.293	6.289	6.286	6.286	6.282	6.280	6.281	6.277	6.275	6.273	6.271	6.268	6.264	6.264	6.262	6.263	6.260
St dev	0.0043	0.0064	0.0073	0.0063	0.0065	0.0070	0.0062	0.0074	0.0056	0.0069	0.0066	0.0054	0.0052	0.0054	0.0059	0.0066	0.0071	0.0077
Min.	6.287	6.280	6.278	6.273	6.273	6.270	6.270	6.266	6.265	6.261	6.262	6.262	6.257	6.257	6.250	6.252	6.248	6.248
Max.	6.300	6.302	6.302	6.296	6.296	6.293	6.292	6.289	6.286	6.287	6.287	6.281	6.279	6.279	6.273	6.272	6.272	6.271

## 3.3 Data Set 1, 55°C, 800mA (Chromaticity Shift)

Sample Number	u'	v'	CCT (K)	Chromaticity Shift ( $\Delta u'v'$ )																
				0hr (Initial)	1000 hrs	2000 hrs	3000 hrs	4000 hrs	5000 hrs	6000 hrs	7000 hrs	8000 hrs	9000 hrs	10000hrs	11000hrs	12000hrs	13000hrs	14000hrs	15000hrs	16000hrs
S1	0.2593	0.5233	2787	0.0001	0.0004	0.0005	0.0006	0.0007	0.0008	0.0009	0.0009	0.0009	0.0010	0.0011	0.0011	0.0011	0.0012	0.0012	0.0013	
S2	0.2583	0.5235	2806	0.0001	0.0002	0.0004	0.0005	0.0005	0.0006	0.0006	0.0007	0.0008	0.0009	0.0009	0.0010	0.0010	0.0011	0.0011	0.0012	0.0013
S3	0.2582	0.5235	2809	0.0001	0.0002	0.0004	0.0005	0.0006	0.0006	0.0006	0.0007	0.0007	0.0008	0.0008	0.0008	0.0009	0.0010	0.0010	0.0011	0.0012
S4	0.2581	0.5232	2812	0.0002	0.0003	0.0005	0.0006	0.0006	0.0006	0.0007	0.0008	0.0008	0.0009	0.0009	0.0010	0.0010	0.0010	0.0010	0.0011	0.0011
S5	0.2583	0.5233	2808	0.0002	0.0003	0.0005	0.0006	0.0006	0.0007	0.0008	0.0008	0.0009	0.0009	0.0010	0.0011	0.0011	0.0011	0.0012	0.0012	0.0013
S6	0.2579	0.5234	2816	0.0001	0.0003	0.0005	0.0007	0.0007	0.0007	0.0008	0.0009	0.0010	0.0010	0.0010	0.0010	0.0011	0.0012	0.0012	0.0013	0.0013
S7	0.2584	0.5236	2803	0.0001	0.0002	0.0005	0.0006	0.0006	0.0006	0.0007	0.0008	0.0009	0.0009	0.0010	0.0010	0.0011	0.0012	0.0013	0.0013	0.0014
S8	0.2585	0.5237	2801	0.0001	0.0004	0.0005	0.0006	0.0007	0.0007	0.0008	0.0008	0.0009	0.0010	0.0011	0.0011	0.0011	0.0012	0.0012	0.0012	0.0012
S9	0.2583	0.5235	2806	0.0001	0.0002	0.0004	0.0006	0.0006	0.0006	0.0007	0.0007	0.0008	0.0009	0.0010	0.0010	0.0011	0.0012	0.0013	0.0013	0.0013
S10	0.2588	0.5238	2795	0.0001	0.0003	0.0005	0.0007	0.0008	0.0008	0.0009	0.0009	0.0009	0.0010	0.0010	0.0011	0.0011	0.0012	0.0012	0.0013	0.0013
S11	0.2579	0.5235	2817	0.0001	0.0003	0.0004	0.0005	0.0005	0.0006	0.0007	0.0007	0.0007	0.0007	0.0008	0.0009	0.0009	0.0010	0.0010	0.0011	0.0011
S12	0.2581	0.5230	2813	0.0001	0.0002	0.0003	0.0006	0.0006	0.0006	0.0006	0.0007	0.0008	0.0008	0.0009	0.0009	0.0009	0.0010	0.0011	0.0012	0.0012
S13	0.2588	0.5218	2804	0.0001	0.0003	0.0006	0.0007	0.0008	0.0008	0.0008	0.0009	0.0010	0.0010	0.0010	0.0011	0.0011	0.0011	0.0012	0.0012	0.0013
S14	0.2587	0.5217	2807	0.0002	0.0003	0.0005	0.0006	0.0007	0.0007	0.0008	0.0009	0.0009	0.0010	0.0010	0.0011	0.0012	0.0012	0.0012	0.0013	0.0013
S15	0.2585	0.5215	2811	0.0001	0.0002	0.0005	0.0006	0.0006	0.0007	0.0008	0.0008	0.0009	0.0009	0.0010	0.0011	0.0012	0.0012	0.0012	0.0012	0.0012
S16	0.2588	0.5216	2806	0.0001	0.0003	0.0004	0.0006	0.0007	0.0008	0.0009	0.0009	0.0010	0.0011	0.0012	0.0013	0.0013	0.0013	0.0014	0.0014	0.0014
S17	0.2583	0.5217	2815	0.0001	0.0003	0.0006	0.0007	0.0007	0.0008	0.0008	0.0008	0.0009	0.0009	0.0009	0.0010	0.0010	0.0011	0.0012	0.0013	0.0013
S18	0.2588	0.5218	2803	0.0001	0.0003	0.0005	0.0006	0.0007	0.0007	0.0007	0.0008	0.0008	0.0009	0.0009	0.0010	0.0010	0.0011	0.0011	0.0012	0.0013
S19	0.2590	0.5221	2798	0.0001	0.0002	0.0003	0.0005	0.0006	0.0006	0.0007	0.0007	0.0008	0.0008	0.0008	0.0009	0.0009	0.0009	0.0009	0.0010	0.0011
S20	0.2593	0.5221	2791	0.0002	0.0004	0.0005	0.0007	0.0007	0.0008	0.0009	0.0009	0.0010	0.0010	0.0011	0.0011	0.0012	0.0012	0.0012	0.0012	0.0013
S21	0.2581	0.5216	2820	0.0001	0.0003	0.0005	0.0006	0.0006	0.0006	0.0007	0.0007	0.0007	0.0007	0.0008	0.0008	0.0009	0.0010	0.0010	0.0011	0.0011
S22	0.2584	0.5212	2816	0.0001	0.0004	0.0006	0.0008	0.0008	0.0008	0.0009	0.0009	0.0009	0.0009	0.0010	0.0011	0.0011	0.0012	0.0013	0.0014	0.0014
S23	0.2602	0.5246	2761	0.0001	0.0004	0.0005	0.0007	0.0007	0.0007	0.0007	0.0008	0.0009	0.0009	0.0010	0.0010	0.0011	0.0012	0.0012	0.0013	0.0014
S24	0.2603	0.5247	2758	0.0001	0.0004	0.0005	0.0007	0.0008	0.0008	0.0008	0.0008	0.0009	0.0009	0.0010	0.0010	0.0011	0.0012	0.0013	0.0014	0.0014
S25	0.2602	0.5246	2760	0.0001	0.0004	0.0006	0.0007	0.0008	0.0008	0.0009	0.0009	0.0010	0.0010	0.0010	0.0011	0.0012	0.0013	0.0013	0.0013	0.0014
Ave.	0.2587	0.5229	2801	0.0001	0.0003	0.0005	0.0006	0.0007	0.0007	0.0008	0.0008	0.0009	0.0009	0.0010	0.0010	0.0011	0.0011	0.0012	0.0012	0.0013
Med.	0.2585	0.5233	2806	0.0001	0.0003	0.0005	0.0006	0.0007	0.0007	0.0008	0.0008	0.0009	0.0009	0.0010	0.0010	0.0011	0.0012	0.0012	0.0012	0.0013
St dev	0.0007	0.0011	17.4879	0.0000	0.0001	0.0001	0.0001	0.0001	0.0001	0.0001	0.0001	0.0001	0.0001	0.0001	0.0001	0.0001	0.0001	0.0001	0.0001	0.0001
Min.	0.2579	0.5212	2758	0.0001	0.0002	0.0003	0.0005	0.0005	0.0006	0.0006	0.0007	0.0007	0.0007	0.0008	0.0008	0.0009	0.0009	0.0010	0.0010	0.0011
Max.	0.2603	0.5247	2820	0.0002	0.0004	0.0006	0.0008	0.0008	0.0008	0.0009	0.0009	0.0010	0.0011	0.0012	0.0013	0.0013	0.0013	0.0014	0.0014	0.0014

**3.4 Data Set 2, 85°C, 800mA (Lumen Maintenance)**

Sample Number	Φ(lm) 0hr (Initial)	Lumen Maintenance (%)																
		1000 hrs	2000 hrs	3000 hrs	4000 hrs	5000 hrs	6000 hrs	7000 hrs	8000 hrs	9000 hrs	10000 hrs	11000 hrs	12000 hrs	13000 hrs	14000 hrs	15000 hrs	16000 hrs	17000 hrs
S26	644.19	100.07	99.91	99.73	99.54	99.36	99.17	99.01	98.87	98.72	98.61	98.54	98.48	98.39	98.27	98.20	98.13	98.04
S27	645.81	100.10	99.93	99.71	99.49	99.28	99.06	98.92	98.76	98.62	98.48	98.40	98.33	98.22	98.15	98.08	98.00	97.92
S28	643.99	100.05	99.93	99.70	99.49	99.30	99.08	98.93	98.78	98.64	98.51	98.42	98.36	98.27	98.18	98.11	98.03	97.95
S29	645.62	100.11	99.96	99.76	99.54	99.36	99.20	99.06	98.92	98.78	98.66	98.57	98.45	98.34	98.25	98.16	98.08	98.00
S30	643.64	100.08	99.92	99.74	99.53	99.34	99.15	99.01	98.85	98.71	98.54	98.42	98.33	98.24	98.15	98.10	98.05	97.96
S31	643.29	100.05	99.93	99.75	99.56	99.35	99.16	99.01	98.86	98.72	98.59	98.50	98.44	98.32	98.21	98.14	98.06	97.98
S32	643.55	100.05	99.93	99.75	99.56	99.35	99.16	99.02	98.88	98.72	98.60	98.52	98.40	98.31	98.19	98.14	98.07	97.98
S33	642.06	100.06	99.90	99.71	99.49	99.28	99.09	98.95	98.79	98.63	98.50	98.38	98.26	98.19	98.12	98.02	97.95	97.87
S34	645.32	100.07	99.91	99.68	99.49	99.30	99.09	98.93	98.77	98.61	98.48	98.39	98.30	98.23	98.12	98.05	97.98	97.91
S35	644.96	100.09	99.93	99.70	99.51	99.29	99.11	98.96	98.82	98.68	98.56	98.44	98.38	98.31	98.24	98.14	98.09	98.03
S36	642.99	100.07	99.90	99.68	99.49	99.27	99.08	98.94	98.80	98.64	98.51	98.42	98.34	98.27	98.18	98.08	98.01	97.92
S37	643.85	100.05	99.93	99.71	99.52	99.34	99.15	99.01	98.89	98.74	98.63	98.51	98.40	98.31	98.24	98.17	98.10	98.01
S38	644.38	100.10	99.98	99.75	99.56	99.37	99.19	99.03	98.89	98.75	98.63	98.51	98.39	98.30	98.21	98.12	98.04	97.98
S39	644.51	100.05	99.88	99.66	99.44	99.25	99.07	98.91	98.77	98.65	98.53	98.41	98.29	98.18	98.11	98.06	97.98	97.92
S40	645.81	100.03	99.87	99.64	99.45	99.27	99.08	98.93	98.79	98.65	98.52	98.45	98.36	98.27	98.16	98.09	98.04	97.97
S41	645.98	100.09	99.97	99.79	99.58	99.36	99.15	99.01	98.87	98.72	98.59	98.50	98.42	98.35	98.24	98.16	98.09	98.01
S42	642.74	100.05	99.93	99.70	99.52	99.30	99.12	98.98	98.83	98.69	98.52	98.40	98.34	98.25	98.16	98.09	98.03	97.97
S43	643.24	100.04	99.88	99.65	99.47	99.28	99.09	98.95	98.81	98.67	98.55	98.46	98.37	98.30	98.21	98.11	98.06	97.98
S44	643.78	100.11	99.99	99.81	99.60	99.41	99.22	99.07	98.92	98.78	98.61	98.55	98.48	98.39	98.32	98.27	98.20	98.11
S45	644.91	100.08	99.91	99.68	99.50	99.31	99.12	98.98	98.84	98.68	98.55	98.46	98.40	98.30	98.19	98.12	98.07	98.00
S46	644.19	100.09	99.92	99.74	99.55	99.37	99.18	99.04	98.90	98.76	98.64	98.58	98.51	98.42	98.31	98.21	98.14	98.08
S47	644.48	100.05	99.89	99.66	99.47	99.26	99.07	98.93	98.79	98.65	98.51	98.43	98.34	98.27	98.16	98.07	97.99	97.93
S48	644.16	100.02	99.85	99.65	99.47	99.28	99.09	98.96	98.82	98.69	98.55	98.43	98.31	98.23	98.16	98.09	98.02	97.96
S49	645.59	100.06	99.94	99.77	99.58	99.39	99.20	99.06	98.90	98.76	98.59	98.47	98.40	98.33	98.22	98.15	98.07	97.99
S50	643.77	100.10	99.99	99.76	99.55	99.36	99.17	99.03	98.89	98.74	98.61	98.52	98.44	98.32	98.25	98.18	98.11	98.05
Ave.	644.27	100.07	99.92	99.72	99.52	99.32	99.13	98.98	98.84	98.70	98.56	98.47	98.38	98.29	98.20	98.12	98.06	97.98
Med.	644.19	100.07	99.93	99.71	99.52	99.31	99.12	98.98	98.84	98.69	98.55	98.46	98.38	98.30	98.19	98.12	98.06	97.98
St dev	1.0389	0.0253	0.0366	0.0469	0.0434	0.0454	0.0489	0.0481	0.0502	0.0512	0.0529	0.0583	0.0625	0.0603	0.0564	0.0565	0.0558	0.0548
Min.	642.06	100.02	99.85	99.64	99.44	99.25	99.06	98.91	98.76	98.61	98.48	98.38	98.26	98.18	98.11	98.02	97.95	97.87
Max.	645.98	100.11	99.99	99.81	99.60	99.41	99.22	99.07	98.92	98.78	98.66	98.58	98.51	98.42	98.32	98.27	98.20	98.11

**3.5 Data Set 2, 85°C, 800mA (Forward Voltage)**

Sample Number	Forward Voltage(V)																	
	0hr (Initial)	1000 hrs	2000 hrs	3000 hrs	4000 hrs	5000 hrs	6000 hrs	7000 hrs	8000 hrs	9000 hrs	10000 hrs	11000 hrs	12000 hrs	13000 hrs	14000 hrs	15000 hrs	16000 hrs	17000hrs
S26	6.295	6.289	6.292	6.289	6.292	6.283	6.281	6.279	6.279	6.278	6.276	6.272	6.270	6.266	6.260	6.259	6.253	6.257
S27	6.300	6.292	6.290	6.291	6.287	6.287	6.289	6.284	6.282	6.283	6.275	6.285	6.279	6.271	6.269	6.271	6.262	6.263
S28	6.281	6.276	6.277	6.273	6.276	6.268	6.270	6.270	6.265	6.261	6.262	6.258	6.258	6.252	6.252	6.249	6.253	6.243
S29	6.299	6.290	6.290	6.291	6.287	6.294	6.283	6.280	6.281	6.283	6.276	6.276	6.270	6.271	6.268	6.265	6.266	6.260
S30	6.300	6.296	6.291	6.291	6.291	6.288	6.286	6.289	6.282	6.280	6.273	6.279	6.277	6.272	6.274	6.265	6.273	6.260
S31	6.292	6.296	6.283	6.287	6.284	6.289	6.282	6.286	6.274	6.282	6.265	6.268	6.270	6.260	6.267	6.261	6.262	6.254
S32	6.281	6.281	6.277	6.278	6.268	6.273	6.265	6.262	6.263	6.264	6.266	6.258	6.259	6.250	6.249	6.246	6.243	6.254
S33	6.283	6.286	6.275	6.283	6.270	6.270	6.267	6.267	6.265	6.261	6.262	6.257	6.261	6.252	6.254	6.252	6.255	6.250
S34	6.295	6.291	6.287	6.287	6.282	6.287	6.284	6.277	6.279	6.272	6.269	6.272	6.266	6.267	6.263	6.259	6.257	6.255
S35	6.293	6.296	6.283	6.284	6.290	6.280	6.275	6.279	6.275	6.271	6.266	6.270	6.265	6.264	6.257	6.261	6.263	6.264
S36	6.296	6.290	6.293	6.290	6.291	6.293	6.285	6.285	6.278	6.274	6.269	6.272	6.268	6.271	6.264	6.264	6.268	6.259
S37	6.287	6.287	6.278	6.288	6.284	6.284	6.268	6.273	6.271	6.264	6.260	6.268	6.259	6.266	6.259	6.256	6.258	6.248
S38	6.294	6.297	6.294	6.289	6.291	6.281	6.284	6.283	6.275	6.274	6.267	6.273	6.263	6.265	6.262	6.263	6.257	6.261
S39	6.286	6.289	6.278	6.280	6.281	6.276	6.280	6.268	6.268	6.274	6.263	6.262	6.257	6.258	6.263	6.252	6.248	6.247
S40	6.291	6.287	6.281	6.282	6.288	6.282	6.275	6.273	6.273	6.269	6.272	6.265	6.263	6.262	6.262	6.266	6.252	6.262
S41	6.288	6.291	6.280	6.285	6.276	6.275	6.272	6.272	6.270	6.266	6.269	6.267	6.264	6.256	6.260	6.259	6.246	6.260
S42	6.292	6.292	6.284	6.288	6.279	6.279	6.276	6.274	6.279	6.274	6.268	6.268	6.264	6.269	6.261	6.257	6.254	6.253
S43	6.297	6.300	6.298	6.287	6.284	6.284	6.283	6.286	6.283	6.277	6.278	6.278	6.269	6.268	6.272	6.268	6.267	6.255
S44	6.300	6.295	6.292	6.291	6.288	6.291	6.282	6.282	6.281	6.278	6.277	6.279	6.278	6.268	6.271	6.266	6.270	6.267
S45	6.282	6.275	6.278	6.272	6.279	6.269	6.269	6.266	6.264	6.264	6.266	6.258	6.260	6.254	6.256	6.251	6.252	6.251
S46	6.290	6.283	6.286	6.287	6.280	6.278	6.272	6.272	6.272	6.273	6.269	6.267	6.269	6.259	6.262	6.267	6.252	6.260
S47	6.280	6.283	6.280	6.270	6.275	6.277	6.266	6.269	6.262	6.263	6.254	6.259	6.249	6.259	6.251	6.251	6.243	6.243
S48	6.298	6.296	6.299	6.293	6.290	6.290	6.284	6.292	6.285	6.287	6.279	6.271	6.267	6.273	6.263	6.267	6.260	6.260
S49	6.291	6.284	6.288	6.291	6.288	6.278	6.277	6.273	6.273	6.274	6.276	6.267	6.269	6.260	6.259	6.268	6.262	6.253
S50	6.285	6.279	6.285	6.275	6.279	6.277	6.267	6.267	6.267	6.265	6.262	6.261	6.257	6.260	6.254	6.253	6.247	6.245
Ave.	6.291	6.289	6.286	6.285	6.283	6.281	6.277	6.276	6.274	6.272	6.269	6.268	6.265	6.263	6.261	6.260	6.257	6.255
Med.	6.292	6.290	6.285	6.287	6.284	6.281	6.277	6.274	6.274	6.274	6.269	6.268	6.265	6.264	6.262	6.261	6.257	6.255
St dev	0.0065	0.0067	0.0069	0.0066	0.0068	0.0074	0.0074	0.0081	0.0069	0.0075	0.0064	0.0077	0.0070	0.0068	0.0067	0.0071	0.0083	0.0067
Min.	6.280	6.275	6.275	6.270	6.268	6.268	6.265	6.262	6.262	6.261	6.254	6.257	6.249	6.250	6.249	6.246	6.243	6.243
Max.	6.300	6.300	6.299	6.293	6.292	6.294	6.289	6.292	6.285	6.287	6.279	6.285	6.279	6.273	6.274	6.271	6.273	6.267

**3.6 Data Set 2, 85°C, 800mA (Chromaticity Shift)**

Sample Number	u'	v'	CCT (K)	Chromaticity Shift ( $\Delta u'v'$ )																
				0hr (Initial)	1000 hrs	2000 hrs	3000 hrs	4000 hrs	5000 hrs	6000 hrs	7000 hrs	8000 hrs	9000 hrs	10000hrs	11000hrs	12000hrs	13000hrs	14000hrs	15000hrs	16000hrs
S26	0.2602	0.5246	2759	0.0001	0.0003	0.0005	0.0007	0.0009	0.0010	0.0012	0.0014	0.0015	0.0017	0.0019	0.0022	0.0023	0.0027	0.0029	0.0030	0.0032
S27	0.2598	0.5246	2768	0.0002	0.0005	0.0006	0.0008	0.0009	0.0011	0.0013	0.0015	0.0017	0.0019	0.0020	0.0022	0.0024	0.0028	0.0030	0.0032	0.0034
S28	0.2603	0.5249	2756	0.0003	0.0005	0.0006	0.0009	0.0010	0.0010	0.0012	0.0014	0.0015	0.0017	0.0018	0.0021	0.0022	0.0025	0.0027	0.0028	0.0030
S29	0.2605	0.5250	2752	0.0002	0.0005	0.0007	0.0010	0.0012	0.0014	0.0016	0.0018	0.0019	0.0020	0.0022	0.0025	0.0028	0.0030	0.0032	0.0033	0.0034
S30	0.2601	0.5246	2763	0.0003	0.0005	0.0008	0.0010	0.0012	0.0013	0.0015	0.0017	0.0018	0.0019	0.0020	0.0023	0.0025	0.0026	0.0027	0.0029	0.0030
S31	0.2608	0.5250	2746	0.0002	0.0003	0.0006	0.0009	0.0011	0.0013	0.0015	0.0017	0.0017	0.0019	0.0020	0.0023	0.0027	0.0031	0.0035	0.0037	0.0039
S32	0.2598	0.5247	2768	0.0001	0.0002	0.0004	0.0006	0.0009	0.0011	0.0013	0.0015	0.0016	0.0017	0.0019	0.0021	0.0022	0.0023	0.0027	0.0030	0.0032
S33	0.2599	0.5241	2768	0.0001	0.0002	0.0004	0.0006	0.0008	0.0010	0.0012	0.0014	0.0015	0.0016	0.0017	0.0020	0.0021	0.0022	0.0023	0.0024	0.0025
S34	0.2583	0.5225	2811	0.0001	0.0002	0.0004	0.0006	0.0009	0.0010	0.0011	0.0013	0.0014	0.0015	0.0017	0.0020	0.0022	0.0024	0.0025	0.0028	0.0029
S35	0.2583	0.5224	2812	0.0002	0.0004	0.0007	0.0009	0.0012	0.0013	0.0016	0.0018	0.0018	0.0020	0.0022	0.0025	0.0026	0.0027	0.0028	0.0029	0.0031
S36	0.2582	0.5221	2817	0.0001	0.0003	0.0006	0.0008	0.0011	0.0012	0.0014	0.0016	0.0017	0.0019	0.0020	0.0023	0.0025	0.0026	0.0027	0.0028	0.0030
S37	0.2583	0.5223	2812	0.0003	0.0005	0.0008	0.0010	0.0012	0.0013	0.0015	0.0017	0.0018	0.0020	0.0021	0.0024	0.0027	0.0029	0.0030	0.0033	0.0035
S38	0.2579	0.5223	2822	0.0002	0.0005	0.0006	0.0009	0.0011	0.0013	0.0014	0.0016	0.0017	0.0018	0.0020	0.0023	0.0024	0.0025	0.0029	0.0031	0.0034
S39	0.2584	0.5225	2809	0.0001	0.0002	0.0004	0.0007	0.0010	0.0010	0.0012	0.0015	0.0016	0.0018	0.0019	0.0022	0.0023	0.0027	0.0028	0.0029	0.0031
S40	0.2586	0.5227	2805	0.0002	0.0003	0.0004	0.0006	0.0009	0.0009	0.0011	0.0013	0.0014	0.0016	0.0018	0.0020	0.0021	0.0022	0.0023	0.0024	0.0025
S41	0.2583	0.5222	2813	0.0001	0.0004	0.0006	0.0009	0.0012	0.0014	0.0016	0.0017	0.0019	0.0021	0.0022	0.0025	0.0027	0.0028	0.0029	0.0031	0.0033
S42	0.2588	0.5227	2800	0.0003	0.0004	0.0005	0.0007	0.0009	0.0010	0.0012	0.0014	0.0015	0.0017	0.0019	0.0021	0.0022	0.0024	0.0026	0.0027	0.0029
S43	0.2577	0.5224	2825	0.0001	0.0003	0.0004	0.0007	0.0008	0.0010	0.0012	0.0013	0.0015	0.0017	0.0019	0.0022	0.0023	0.0024	0.0025	0.0027	0.0029
S44	0.2581	0.5218	2820	0.0003	0.0004	0.0005	0.0008	0.0010	0.0012	0.0014	0.0016	0.0017	0.0018	0.0020	0.0022	0.0024	0.0028	0.0032	0.0034	0.0036
S45	0.2599	0.5236	2772	0.0002	0.0004	0.0006	0.0009	0.0010	0.0012	0.0013	0.0015	0.0016	0.0018	0.0019	0.0022	0.0025	0.0029	0.0033	0.0034	0.0036
S46	0.2598	0.5232	2776	0.0003	0.0004	0.0006	0.0009	0.0012	0.0014	0.0015	0.0018	0.0018	0.0019	0.0021	0.0024	0.0028	0.0032	0.0033	0.0035	0.0036
S47	0.2600	0.5236	2769	0.0002	0.0003	0.0006	0.0008	0.0011	0.0011	0.0013	0.0015	0.0016	0.0017	0.0019	0.0022	0.0023	0.0026	0.0028	0.0030	0.0033
S48	0.2601	0.5238	2765	0.0002	0.0004	0.0006	0.0008	0.0010	0.0012	0.0014	0.0016	0.0017	0.0019	0.0021	0.0023	0.0025	0.0027	0.0028	0.0030	0.0033
S49	0.2603	0.5238	2761	0.0002	0.0003	0.0006	0.0007	0.0009	0.0010	0.0013	0.0015	0.0016	0.0017	0.0019	0.0022	0.0023	0.0024	0.0027	0.0030	0.0033
S50	0.2594	0.5234	2784	0.0001	0.0004	0.0006	0.0009	0.0012	0.0013	0.0015	0.0017	0.0018	0.0020	0.0021	0.0024	0.0028	0.0029	0.0031	0.0032	0.0033
Ave.	0.2593	0.5234	2786	0.0002	0.0004	0.0006	0.0008	0.0010	0.0012	0.0014	0.0015	0.0016	0.0018	0.0020	0.0022	0.0024	0.0026	0.0028	0.0030	0.0032
Med.	0.2598	0.5234	2776	0.0002	0.0004	0.0006	0.0008	0.0010	0.0012	0.0013	0.0015	0.0017	0.0018	0.0020	0.0022	0.0024	0.0027	0.0028	0.0030	0.0033
St dev	0.0010	0.0011	26.0341	0.0001	0.0001	0.0001	0.0001	0.0001	0.0002	0.0002	0.0002	0.0002	0.0002	0.0001	0.0001	0.0002	0.0003	0.0003	0.0003	0.0003
Min.	0.2577	0.5218	2746	0.0001	0.0002	0.0004	0.0006	0.0008	0.0009	0.0011	0.0013	0.0014	0.0015	0.0017	0.0020	0.0021	0.0022	0.0023	0.0024	0.0025
Max.	0.2608	0.5250	2825	0.0003	0.0005	0.0008	0.0010	0.0012	0.0014	0.0016	0.0018	0.0019	0.0021	0.0022	0.0025	0.0028	0.0032	0.0035	0.0037	0.0039

## 3.7 Data Set 3, 105°C, 800mA (Lumen Maintenance)

Sample Number	Φ(lm) 0hr (Initial)	Lumen Maintenance (%)																
		1000 hrs	2000 hrs	3000 hrs	4000 hrs	5000 hrs	6000 hrs	7000 hrs	8000 hrs	9000 hrs	10000 hrs	11000 hrs	12000 hrs	13000 hrs	14000 hrs	15000 hrs	16000 hrs	17000 hrs
S51	643.22	99.86	99.69	99.47	99.26	99.02	98.81	98.64	98.48	98.31	98.10	97.93	97.74	97.57	97.40	97.26	97.11	97.03
S52	644.32	99.89	99.68	99.47	99.26	99.03	98.79	98.58	98.41	98.24	98.04	97.87	97.68	97.48	97.31	97.17	97.06	96.94
S53	644.63	99.92	99.75	99.58	99.38	99.18	98.94	98.73	98.56	98.39	98.19	98.01	97.83	97.66	97.49	97.35	97.19	97.07
S54	645.35	99.89	99.67	99.51	99.30	99.10	98.86	98.70	98.53	98.33	98.16	97.98	97.80	97.63	97.46	97.28	97.18	97.10
S55	643.62	99.90	99.73	99.52	99.31	99.11	98.89	98.68	98.49	98.27	98.07	97.92	97.74	97.54	97.37	97.23	97.07	96.95
S56	642.42	99.93	99.76	99.55	99.35	99.14	98.93	98.71	98.52	98.33	98.12	97.95	97.76	97.59	97.39	97.25	97.14	97.03
S57	644.95	99.95	99.78	99.61	99.38	99.16	98.95	98.75	98.59	98.39	98.19	98.01	97.83	97.63	97.43	97.25	97.11	96.99
S58	643.56	99.93	99.76	99.55	99.33	99.12	98.90	98.69	98.48	98.26	98.08	97.94	97.78	97.61	97.44	97.27	97.11	96.99
S59	644.19	99.95	99.74	99.57	99.35	99.15	98.91	98.70	98.49	98.32	98.12	97.94	97.76	97.55	97.35	97.21	97.06	96.98
S60	643.83	99.92	99.75	99.54	99.31	99.07	98.87	98.67	98.51	98.31	98.11	97.93	97.75	97.58	97.41	97.27	97.12	97.04
S61	642.43	99.92	99.75	99.53	99.32	99.11	98.90	98.73	98.56	98.40	98.22	98.05	97.86	97.69	97.52	97.35	97.24	97.13
S62	644.16	99.91	99.70	99.48	99.25	99.03	98.83	98.64	98.44	98.27	98.07	97.90	97.74	97.57	97.37	97.23	97.12	97.00
S63	643.79	99.91	99.70	99.53	99.33	99.09	98.88	98.67	98.50	98.28	98.11	97.93	97.75	97.58	97.41	97.24	97.08	96.96
S64	642.93	99.85	99.64	99.43	99.21	99.01	98.77	98.56	98.39	98.18	98.00	97.85	97.67	97.47	97.26	97.12	97.02	96.89
S65	643.79	99.94	99.77	99.60	99.39	99.18	98.95	98.74	98.54	98.35	98.17	98.00	97.81	97.61	97.41	97.23	97.13	97.01
S66	645.20	99.85	99.63	99.42	99.19	98.98	98.75	98.53	98.34	98.14	97.94	97.76	97.58	97.41	97.24	97.10	96.95	96.83
S67	642.52	99.84	99.63	99.46	99.24	99.03	98.81	98.65	98.48	98.31	98.11	97.96	97.77	97.57	97.40	97.26	97.11	97.00
S68	645.60	99.95	99.78	99.61	99.38	99.17	98.96	98.77	98.60	98.38	98.18	98.01	97.82	97.62	97.42	97.28	97.13	97.00
S69	645.09	99.85	99.68	99.51	99.30	99.06	98.86	98.69	98.50	98.33	98.15	97.98	97.80	97.59	97.42	97.28	97.18	97.06
S70	643.28	99.91	99.70	99.48	99.25	99.04	98.81	98.64	98.45	98.28	98.08	97.93	97.75	97.54	97.34	97.20	97.05	96.93
S71	642.89	99.94	99.77	99.56	99.35	99.11	98.88	98.68	98.52	98.30	98.10	97.95	97.77	97.60	97.43	97.29	97.14	97.06
S72	645.13	99.85	99.68	99.47	99.26	99.05	98.85	98.63	98.44	98.22	98.02	97.85	97.66	97.49	97.32	97.18	97.03	96.91
S73	643.72	99.95	99.79	99.57	99.37	99.13	98.93	98.76	98.55	98.34	98.13	97.98	97.82	97.62	97.42	97.28	97.12	97.00
S74	644.41	99.95	99.74	99.53	99.32	99.12	98.91	98.69	98.48	98.28	98.08	97.90	97.72	97.55	97.35	97.17	97.07	96.95
S75	644.51	99.89	99.72	99.55	99.34	99.10	98.87	98.67	98.51	98.29	98.09	97.94	97.76	97.56	97.39	97.21	97.11	96.98
Ave.	643.98	99.91	99.72	99.52	99.31	99.09	98.87	98.68	98.49	98.30	98.10	97.94	97.76	97.57	97.39	97.24	97.10	96.99
Med.	643.83	99.91	99.73	99.53	99.32	99.10	98.88	98.68	98.50	98.31	98.11	97.94	97.76	97.58	97.40	97.25	97.11	97.00
St dev	0.9434	0.0382	0.0485	0.0543	0.0556	0.0570	0.0582	0.0592	0.0602	0.0619	0.0636	0.0617	0.0625	0.0623	0.0638	0.0596	0.0610	0.0660
Min.	642.42	99.84	99.63	99.42	99.19	98.98	98.75	98.53	98.34	98.14	97.94	97.76	97.58	97.41	97.24	97.10	96.95	96.83
Max.	645.60	99.95	99.79	99.61	99.39	99.18	98.96	98.77	98.60	98.40	98.22	98.05	97.86	97.69	97.52	97.35	97.24	97.13

**3.8 Data Set 3, 105°C, 800mA (Forward Voltage)**

Sample Number	Forward Voltage(V)																	
	0hr (Initial)	1000 hrs	2000 hrs	3000 hrs	4000 hrs	5000 hrs	6000 hrs	7000 hrs	8000 hrs	9000 hrs	10000 hrs	11000 hrs	12000 hrs	13000 hrs	14000 hrs	15000 hrs	16000 hrs	17000hrs
S51	6.295	6.293	6.289	6.288	6.288	6.281	6.286	6.275	6.277	6.280	6.270	6.265	6.265	6.266	6.265	6.256	6.259	6.253
S52	6.300	6.298	6.298	6.294	6.293	6.288	6.285	6.286	6.285	6.278	6.275	6.279	6.273	6.270	6.276	6.264	6.260	6.258
S53	6.286	6.283	6.286	6.284	6.270	6.272	6.277	6.271	6.265	6.269	6.271	6.261	6.265	6.265	6.257	6.251	6.247	6.258
S54	6.297	6.298	6.285	6.285	6.283	6.282	6.283	6.288	6.281	6.272	6.281	6.272	6.280	6.268	6.273	6.261	6.264	6.269
S55	6.288	6.285	6.286	6.276	6.270	6.270	6.274	6.270	6.267	6.263	6.263	6.262	6.271	6.258	6.267	6.248	6.260	6.248
S56	6.295	6.292	6.293	6.289	6.278	6.283	6.281	6.275	6.275	6.278	6.269	6.266	6.273	6.274	6.265	6.267	6.269	6.264
S57	6.298	6.288	6.291	6.296	6.290	6.286	6.280	6.284	6.280	6.273	6.276	6.273	6.268	6.269	6.263	6.263	6.269	6.270
S58	6.294	6.288	6.292	6.283	6.285	6.285	6.285	6.274	6.282	6.269	6.272	6.274	6.268	6.265	6.265	6.258	6.261	6.266
S59	6.288	6.285	6.276	6.276	6.279	6.274	6.271	6.281	6.272	6.272	6.263	6.261	6.261	6.258	6.267	6.258	6.252	6.251
S60	6.289	6.287	6.283	6.289	6.271	6.277	6.275	6.268	6.271	6.274	6.273	6.267	6.263	6.259	6.259	6.261	6.261	6.252
S61	6.296	6.287	6.297	6.290	6.282	6.284	6.282	6.284	6.278	6.281	6.281	6.269	6.280	6.271	6.261	6.268	6.261	6.259
S62	6.300	6.299	6.298	6.293	6.286	6.291	6.285	6.282	6.282	6.275	6.287	6.273	6.284	6.278	6.270	6.271	6.271	6.267
S63	6.294	6.292	6.287	6.282	6.282	6.279	6.285	6.279	6.274	6.278	6.272	6.274	6.265	6.264	6.269	6.264	6.258	6.254
S64	6.291	6.285	6.285	6.279	6.282	6.276	6.277	6.277	6.276	6.266	6.266	6.261	6.265	6.266	6.257	6.265	6.256	6.249
S65	6.286	6.277	6.279	6.275	6.274	6.272	6.273	6.268	6.275	6.270	6.271	6.265	6.259	6.256	6.252	6.251	6.258	6.250
S66	6.300	6.291	6.288	6.293	6.290	6.286	6.285	6.292	6.280	6.284	6.275	6.279	6.273	6.270	6.266	6.261	6.276	6.260
S67	6.292	6.289	6.286	6.280	6.280	6.278	6.280	6.284	6.283	6.267	6.267	6.265	6.267	6.265	6.268	6.266	6.253	6.264
S68	6.286	6.284	6.274	6.279	6.282	6.277	6.268	6.278	6.271	6.261	6.271	6.264	6.256	6.262	6.257	6.260	6.260	6.244
S69	6.293	6.291	6.286	6.287	6.285	6.276	6.278	6.275	6.281	6.272	6.268	6.268	6.272	6.264	6.269	6.263	6.265	6.261
S70	6.290	6.289	6.288	6.290	6.286	6.275	6.278	6.272	6.282	6.268	6.265	6.274	6.260	6.260	6.260	6.266	6.257	6.258
S71	6.289	6.286	6.277	6.277	6.272	6.280	6.280	6.273	6.269	6.267	6.265	6.262	6.262	6.259	6.259	6.261	6.254	6.249
S72	6.300	6.294	6.300	6.294	6.292	6.286	6.286	6.279	6.280	6.285	6.275	6.275	6.275	6.271	6.265	6.267	6.261	6.260
S73	6.283	6.277	6.280	6.276	6.276	6.271	6.274	6.265	6.272	6.270	6.263	6.261	6.254	6.259	6.248	6.255	6.250	6.252
S74	6.291	6.292	6.287	6.287	6.283	6.282	6.279	6.282	6.273	6.266	6.269	6.270	6.265	6.266	6.266	6.255	6.267	6.259
S75	6.287	6.281	6.287	6.283	6.280	6.275	6.273	6.278	6.266	6.272	6.266	6.267	6.265	6.257	6.257	6.258	6.247	6.251
Ave.	6.292	6.289	6.287	6.285	6.282	6.280	6.279	6.278	6.276	6.273	6.271	6.268	6.267	6.265	6.263	6.261	6.260	6.257
Med.	6.292	6.288	6.287	6.285	6.282	6.279	6.280	6.278	6.276	6.272	6.271	6.267	6.265	6.265	6.265	6.261	6.260	6.258
St dev	0.0051	0.0059	0.0068	0.0066	0.0067	0.0058	0.0051	0.0068	0.0058	0.0062	0.0061	0.0057	0.0074	0.0056	0.0066	0.0059	0.0073	0.0072
Min.	6.283	6.277	6.274	6.275	6.270	6.270	6.268	6.265	6.265	6.261	6.263	6.261	6.254	6.256	6.248	6.248	6.247	6.244
Max.	6.300	6.299	6.300	6.296	6.293	6.291	6.286	6.292	6.285	6.285	6.287	6.279	6.284	6.278	6.276	6.271	6.276	6.270

**3.9 Data Set 3, 105°C, 800mA (Chromaticity Shift)**

Sample Number	u'	v'	CCT (K)	Chromaticity Shift ( $\Delta u'v'$ )																
				0hr (Initial)	1000 hrs	2000 hrs	3000 hrs	4000 hrs	5000 hrs	6000 hrs	7000 hrs	8000 hrs	9000 hrs	10000hrs	11000hrs	12000hrs	13000hrs	14000hrs	15000hrs	16000hrs
S51	0.2596	0.5224	2784	0.0003	0.0005	0.0008	0.0010	0.0011	0.0014	0.0016	0.0019	0.0020	0.0022	0.0022	0.0023	0.0026	0.0028	0.0029	0.0032	0.0034
S52	0.2596	0.5223	2784	0.0002	0.0004	0.0007	0.0011	0.0013	0.0014	0.0016	0.0018	0.0019	0.0019	0.0020	0.0022	0.0025	0.0026	0.0028	0.0031	0.0034
S53	0.2594	0.5221	2789	0.0003	0.0005	0.0008	0.0010	0.0012	0.0013	0.0015	0.0018	0.0019	0.0019	0.0019	0.0022	0.0024	0.0026	0.0027	0.0030	0.0033
S54	0.2595	0.5222	2786	0.0003	0.0005	0.0008	0.0010	0.0012	0.0012	0.0015	0.0017	0.0019	0.0020	0.0021	0.0024	0.0026	0.0028	0.0029	0.0032	0.0035
S55	0.2593	0.5223	2792	0.0002	0.0005	0.0007	0.0011	0.0013	0.0015	0.0018	0.0020	0.0021	0.0023	0.0023	0.0025	0.0028	0.0029	0.0031	0.0034	0.0036
S56	0.2597	0.5224	2781	0.0002	0.0004	0.0007	0.0009	0.0013	0.0014	0.0016	0.0019	0.0020	0.0022	0.0023	0.0026	0.0028	0.0030	0.0031	0.0034	0.0036
S57	0.2599	0.5226	2777	0.0002	0.0004	0.0007	0.0010	0.0014	0.0015	0.0017	0.0020	0.0021	0.0022	0.0024	0.0026	0.0029	0.0031	0.0033	0.0035	0.0038
S58	0.2596	0.5221	2785	0.0003	0.0005	0.0008	0.0012	0.0014	0.0015	0.0017	0.0019	0.0020	0.0020	0.0021	0.0023	0.0026	0.0028	0.0029	0.0031	0.0034
S59	0.2601	0.5227	2772	0.0003	0.0005	0.0008	0.0010	0.0014	0.0017	0.0019	0.0021	0.0022	0.0022	0.0022	0.0025	0.0027	0.0029	0.0031	0.0034	0.0036
S60	0.2590	0.5223	2798	0.0003	0.0005	0.0008	0.0012	0.0014	0.0015	0.0018	0.0020	0.0022	0.0023	0.0024	0.0025	0.0028	0.0030	0.0032	0.0035	0.0037
S61	0.2593	0.5217	2793	0.0003	0.0005	0.0007	0.0011	0.0015	0.0016	0.0018	0.0020	0.0021	0.0022	0.0023	0.0026	0.0028	0.0029	0.0031	0.0033	0.0036
S62	0.2591	0.5233	2790	0.0003	0.0005	0.0008	0.0010	0.0013	0.0014	0.0016	0.0019	0.0020	0.0020	0.0022	0.0023	0.0026	0.0028	0.0030	0.0032	0.0035
S63	0.2591	0.5233	2791	0.0002	0.0004	0.0007	0.0009	0.0011	0.0012	0.0014	0.0016	0.0017	0.0017	0.0017	0.0018	0.0020	0.0022	0.0024	0.0027	0.0030
S64	0.2589	0.5230	2795	0.0003	0.0005	0.0008	0.0010	0.0014	0.0016	0.0018	0.0021	0.0022	0.0022	0.0022	0.0023	0.0026	0.0028	0.0030	0.0032	0.0034
S65	0.2590	0.5231	2793	0.0003	0.0005	0.0008	0.0009	0.0011	0.0012	0.0015	0.0018	0.0019	0.0020	0.0021	0.0022	0.0025	0.0027	0.0029	0.0031	0.0034
S66	0.2586	0.5232	2801	0.0002	0.0005	0.0008	0.0011	0.0015	0.0018	0.0020	0.0022	0.0023	0.0025	0.0025	0.0027	0.0030	0.0032	0.0034	0.0037	0.0040
S67	0.2592	0.5234	2788	0.0003	0.0005	0.0008	0.0009	0.0011	0.0014	0.0016	0.0019	0.0020	0.0020	0.0020	0.0021	0.0024	0.0026	0.0027	0.0029	0.0032
S68	0.2594	0.5235	2783	0.0003	0.0005	0.0008	0.0011	0.0015	0.0016	0.0018	0.0021	0.0022	0.0023	0.0024	0.0026	0.0028	0.0030	0.0032	0.0035	0.0037
S69	0.2591	0.5231	2791	0.0003	0.0005	0.0008	0.0010	0.0011	0.0012	0.0014	0.0016	0.0018	0.0018	0.0019	0.0020	0.0022	0.0024	0.0026	0.0029	0.0032
S70	0.2596	0.5236	2778	0.0003	0.0006	0.0008	0.0010	0.0014	0.0017	0.0020	0.0022	0.0023	0.0024	0.0026	0.0028	0.0030	0.0032	0.0034	0.0037	0.0040
S71	0.2588	0.5227	2800	0.0002	0.0005	0.0008	0.0009	0.0013	0.0014	0.0017	0.0019	0.0020	0.0021	0.0023	0.0024	0.0027	0.0029	0.0030	0.0033	0.0036
S72	0.2589	0.5239	2791	0.0003	0.0005	0.0008	0.0010	0.0012	0.0013	0.0015	0.0018	0.0019	0.0019	0.0020	0.0021	0.0023	0.0025	0.0027	0.0030	0.0033
S73	0.2588	0.5237	2796	0.0003	0.0005	0.0007	0.0009	0.0011	0.0012	0.0014	0.0016	0.0017	0.0018	0.0019	0.0020	0.0023	0.0025	0.0027	0.0029	0.0032
S74	0.2589	0.5238	2792	0.0003	0.0005	0.0008	0.0012	0.0014	0.0016	0.0019	0.0021	0.0022	0.0024	0.0025	0.0027	0.0029	0.0031	0.0032	0.0035	0.0038
S75	0.2591	0.5240	2787	0.0003	0.0005	0.0008	0.0010	0.0011	0.0014	0.0016	0.0019	0.0020	0.0021	0.0021	0.0023	0.0026	0.0027	0.0029	0.0031	0.0033
Ave.	0.2593	0.5229	2789	0.0003	0.0005	0.0008	0.0010	0.0013	0.0014	0.0017	0.0019	0.0020	0.0021	0.0022	0.0024	0.0026	0.0028	0.0030	0.0032	0.0035
Med.	0.2592	0.5230	2790	0.0003	0.0005	0.0008	0.0010	0.0013	0.0014	0.0016	0.0019	0.0020	0.0021	0.0022	0.0023	0.0026	0.0028	0.0030	0.0032	0.0035
St dev	0.0004	0.0007	7.1456	0.0000	0.0000	0.0000	0.0001	0.0001	0.0002	0.0002	0.0002	0.0002	0.0002	0.0002	0.0002	0.0003	0.0003	0.0003	0.0003	0.0003
Min.	0.2586	0.5217	2772	0.0002	0.0004	0.0007	0.0009	0.0011	0.0012	0.0014	0.0016	0.0017	0.0017	0.0017	0.0018	0.0020	0.0022	0.0024	0.0027	0.0030
Max.	0.2601	0.5240	2801	0.0003	0.0006	0.0008	0.0012	0.0015	0.0018	0.0020	0.0022	0.0023	0.0025	0.0026	0.0028	0.0030	0.0032	0.0034	0.0037	0.0040

#### 4. EUT Photo

##### 4.1 Mechanical Dimensions

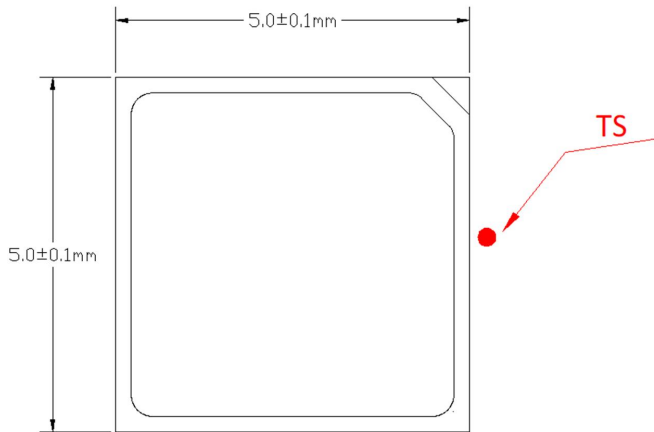

All dimensions are in millimeter

##### 4.2 EUT Photo

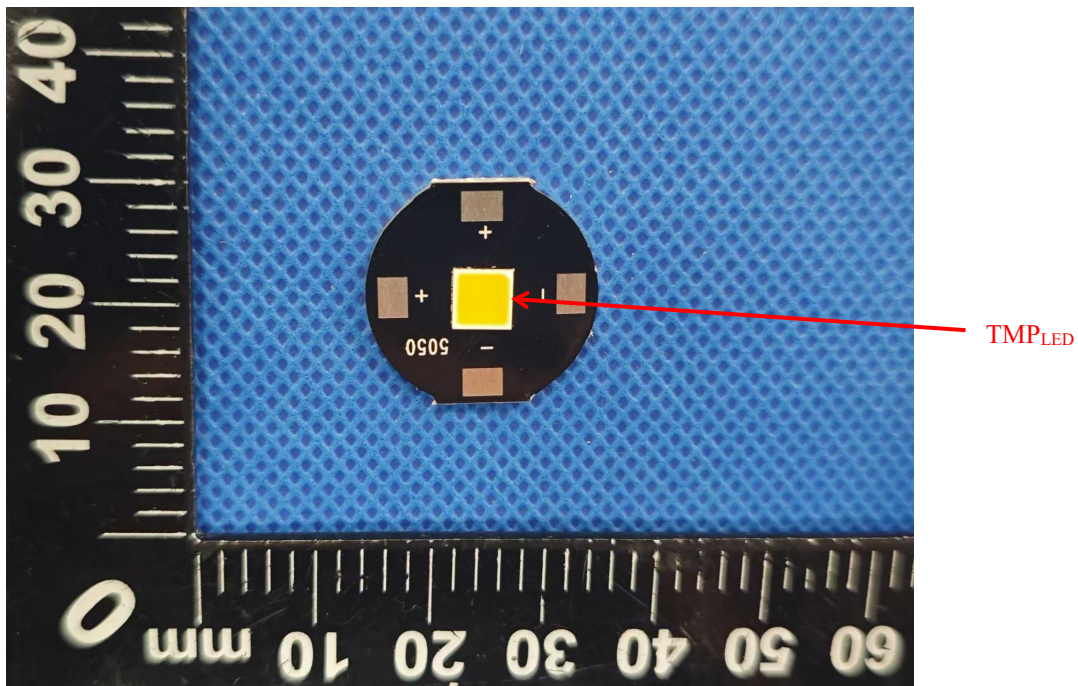

---End of Report---

---

## Appendix :

### Additional Models Covered By Testing

The 28 September 2017 *ENERGY STAR® Requirements for the Use of LM-80 Data defines conditions for which a LM-80 report is applied to cover models that have not been directly tested.*

The test results in this report applies to the following list of models:

- OSCONIQ® S 5050 GW Q9LR33.EM with CCT 2200 K – 6500 K up to 800mA
- OSCONIQ® S 5050 GW Q9LR33.PM with CCT 2200 K – 6500 K up to 800mA
- OSCONIQ® S 5050 GW Q9LR34.EM with CCT 2200 K – 6500 K up to 200mA
- OSCONIQ® S 5050 GW Q9LR34.PM with CCT 2200 K – 6500 K up to 200mA

*Note: The devices were stressed and tested at average current density per LED die of 300mA/mm<sup>2</sup>. This report can be referenced when the current employed in the application is lower than the specified current of the respective devices as stated above.*

---

## Disclaimer

PLEASE CAREFULLY READ THE BELOW TERMS AND CONDITIONS BEFORE USING THE INFORMATION.  
IF YOU DO NOT AGREE WITH ANY OF THESE TERMS AND CONDITIONS, DO NOT USE THE INFORMATION.

The Information contained in this Document does not constitute an independent warranty. The committed behavior is described in the Product data sheet.

Distribution of part or all of the contents of this Document to any 3rd party in any form without the prior permission of ams-OSRAM International GmbH is prohibited except in accordance with applicable mandatory law.

Further explanations:

Data: The Data used in this Document consider the reliability test results under the mentioned driving conditions only. For Product information on the maximum operating conditions please refer to the Product data sheet or contact your local sales partner.

Conditions: The conditions for the generation of the Data are as follows:

1. The Data and curves shown in this Document are based on experiments carried out under laboratory conditions on a random sample size of LED/IRED/Laser with readouts at discrete readout times (where applicable). Thus, the Data above represent a limited number of production lots only and may differ between different assembly lots over time (including chip or package changes). Thus, the behavior of the LED/IRED/Laser in the final application may differ from the Data. The behavior of the LED/IRED/Laser at conditions or readout times deviating from those stated above may not be deduced from the Data.
2. For long term operation additional failure modes of the chip or package can occur which are not shown in this Document.
3. Possible differences in the thermal management of OSRAM and customer's setup may lead to a different aging behavior.
4. The lifetime projection data presented in this Document has been evaluated in accordance with the lifetime extrapolation method described and defined in IES TM-21-11. The lifetime projection is based on the Data shown in this Document. The data had been collected and assembled according to IES LM-80-15.

END OF DOCUMENT